

Feature:

- Commercial PA system Indoor wall-mounted speaker.
- Ideal for school, office, hotel, shop, factory and airport background music system.
- Built-in 100V/70V transformer.
- 5"x1 woofer and 1"x1 tweeter, two way speaker units.
- Power RMS 30W @100V, Maximum power: 60W.
- Material: Metal grille, ABS enclosure and stainless mounting bracket.
- Color: white or black.
- Easy installed by supplied stainless mounting bracket.



Specification:

Model	SP-WE530
Description	Two Way Wall-Mounted Loudspeaker
Rated Power	30W(100V), 15W(70V)
Line Input	100V
Transformer Impedance	Black: Com, Red: 250Ω
Frequency Response	130Hz-15KHz
SPL(@1W/1M)	92dB±3dB
Speaker Unit	5"x1 woofer, 1"x1 treble
Material	plastic shell + iron mesh cover
Color	White or Black
Mounting Method	Easy installed by supplied stainless mounting bracket and screws
Dimension/Net Weight	251x184x158mm(H*W*D), 2.28kg/pc
Package	404*364*275mm, 4pcs / ctn

Dimension and Mounting:

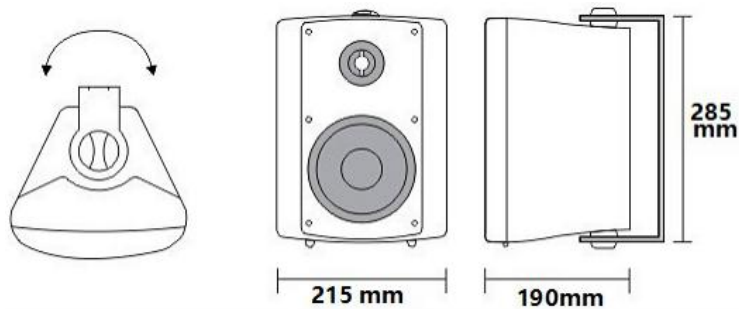

Frequency Response & SPL Diagrams:

